

FOR FURTHER RING DETAILS SEE: RC8038-RS

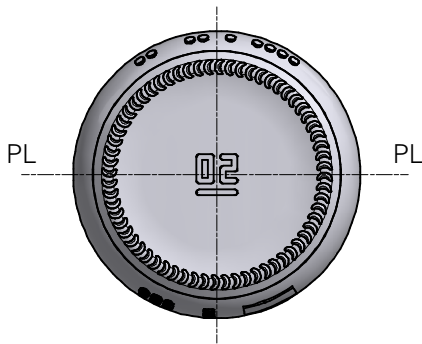
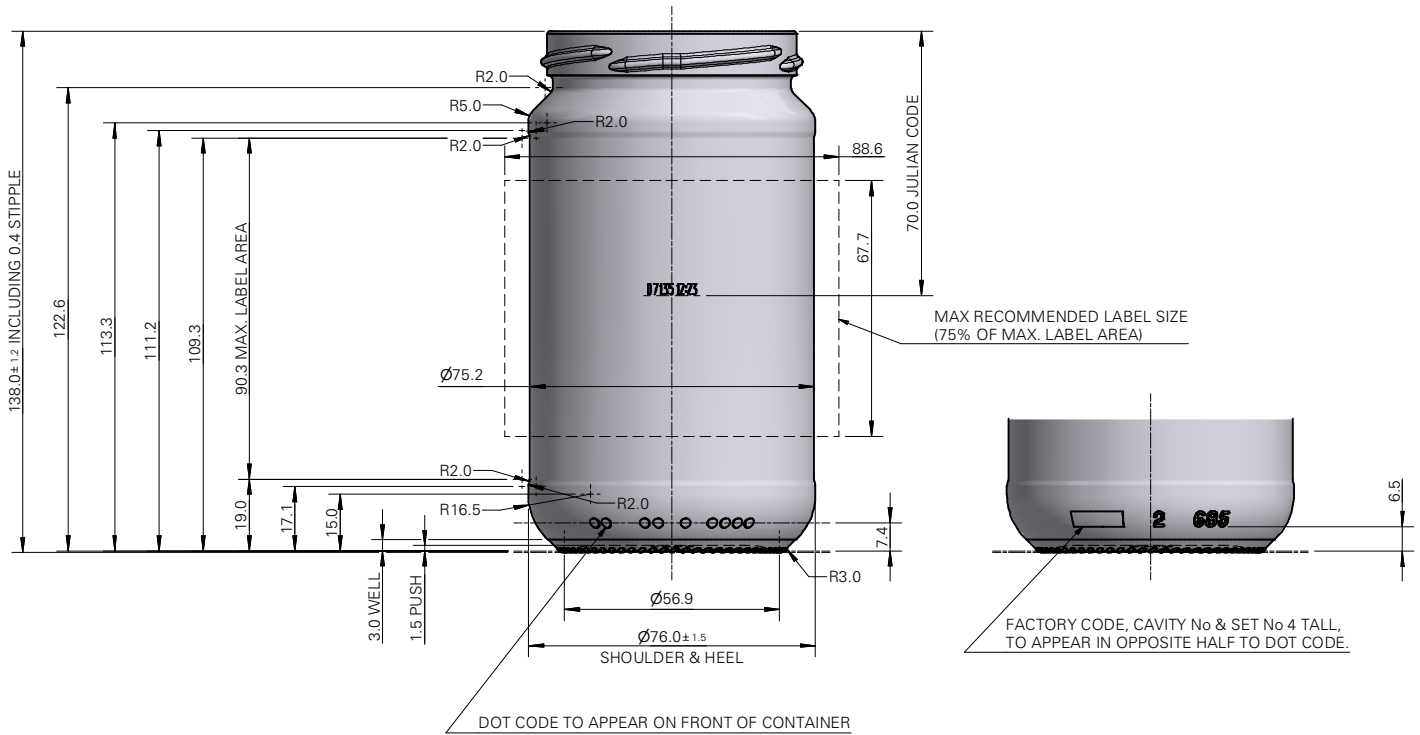

BASE EMBOSHING TO INCLUDE:

LNMC GRID (3.0)

(64) BAR STIPPLES 4.0 LONG TO STD: 5325-G

DESCRIPTION 480ml PICKLE JAR		CAPACITY AT FILL POINT	APPROX. GLASS WEIGHT	251 g	GLASS CONTAINER SPECIFICATION THIS DRAWING IS THE PROPERTY OF VERALLIA UK. REPRODUCTION AND DISTRIBUTION PROHIBITED WITHOUT OUR PRIOR WRITTEN PERMISSION. NON-TOLERANCED DIMENSIONS ARE CONSTRUCTION DIMENSIONS GIVEN FOR INFORMATION ONLY.
PRODUCT FOOD		CAPACITY TOLERANCE	GLASS COLOUR	STD FLINT	
PE No.	PROPOSAL No. 1	VACUITY (excl. FITMENT or CORK)	FINISH DESCRIPTION	70mm FD138 CMB POOLE	
CUSTOMER GENERAL TRADE		FILL BELOW TOP	FINISH SPECIFICATION	RC8038-RS	
DATE 13.10.2000	DRAWN R.W.	CHECKED A.H.	SHEET 1 OF 1	SIZE A2	
3D MODEL REF. G685-8038_GENERAL TRADE_PICKLE JAR_480ml.ipt		MEASURING CONTAINER	RING NECK DIAMETER	63.1mm	
COLOUR COATING NONE		VERTICAL LOAD	2000 N	THERMAL SHOCK	YES
		REFILLABLE	NO	MAX. INT. PRESSURE	NIL
				BAR @20°C	PASTEURISED
					NO

J			
I			
H			
G			
F	REDRAWN ON VERALLIA BORDER.	R.N.	G.C.F.
E	UV CODE CHANGED TO JULIAN CODE (LASER)	G.C.F.	04/10/2017
D	UV CODE ADDED. AC/RW.	R.W.	13.08.2006
C	FACTORY CODE, CAV No MOVED TO HEEL. DOT CODE ADDED.	A.H.	03.12.2002
B	THERMAL SHOCK WAS NIL.	R.W.	23.01.2002
A	REDRAWN ON CAD. ORIGINAL DRGS DATE 9.12.98 REV 1.	R.W.	13.10.2000
REV.	DETAILS	DRN	CKD
SPECIFICATION No.		G685-8038	