

FOR RING DETAILS SEE: RC8038-RS

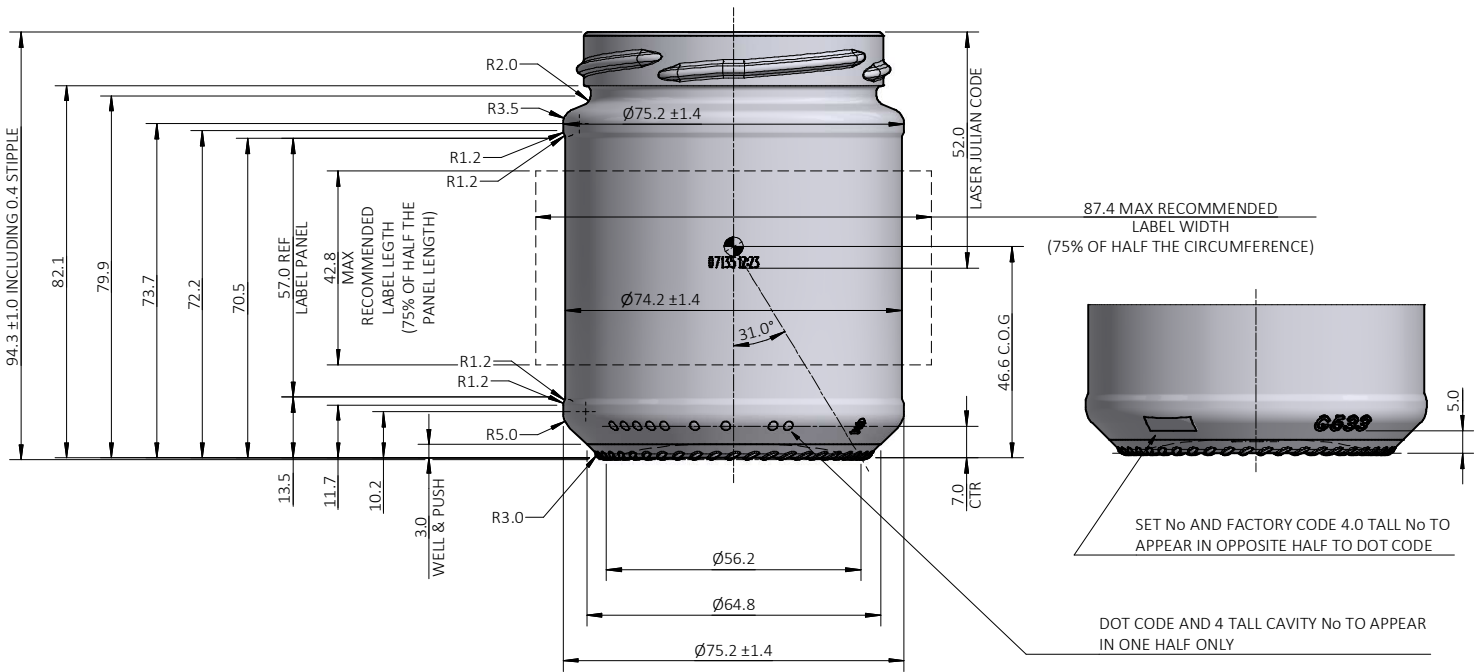

BASE TO INCLUDE ;

LNMC GRID (3.0)

45 CRESCENT STIPPLES 5.0 LONG
TO STD: 5325-G

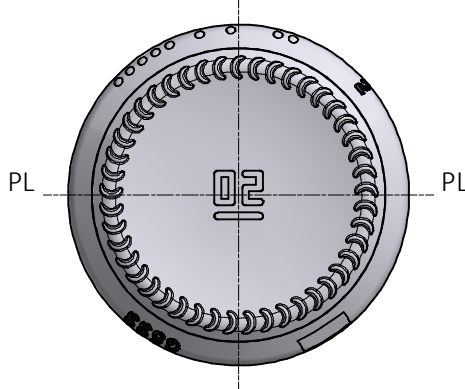

DESCRIPTION

300ML NP JAR	
PRODUCT	FOOD
PE No.	PROPOSAL No. 1
CUSTOMER	GENERAL TRADE
DATE	25.1.95
DRAWN	AH
CHECKED	RW
SHEET	1 OF 1
SIZE	A2
MEASURING CONTAINER	3 ±
BRIMFUL CAPACITY	300 ml
COLOUR	NO
VERTICAL LOAD	2000 N
THERMAL SHOCK	YES °C

CAPACITY AT FILL POINT	ml	APPROX. GLASS WEIGHT	191 g
CAPACITY TOLERANCE	4.6 ml	GLASS COLOUR	STD FLINT
VACUITY (excl. FITMENT or CORK)	%	FINISH DESCRIPTION	70mm CMB POOLE
FILL BELOW TOP	mm	FINISH SPECIFICATION	RC8038-RS
RING NECK DIAMETER	mm	MOULD No.	G533
REFILLABLE	NO	MAX. INT. PRESSURE	NIL
BAR @20°C	NO	PASTEURISED	NO

GLASS CONTAINER SPECIFICATION

THIS DRAWING IS THE PROPERTY OF VERALLIA UK. REPRODUCTION AND DISTRIBUTION PROHIBITED WITHOUT OUR PRIOR WRITTEN PERMISSION. NON-TOLERANCED DIMENSIONS ARE CONSTRUCTION DIMENSIONS GIVEN FOR INFORMATION ONLY.

J			
I			
H			
G	REDRAWN TO LATEST STANDARDS. RECOMMENDED LABEL SIZE DIMS ADDED	MD	LA 15.8.23
F	JULIAN LASER CODE ADDED TO SPEC	GCR	GN 2.8.17
E	SET No AND FACTORY CODE MOVED TO INSWEEP	RW	AH 15.8.03
D	DOT CODE ADDED AT PRODUCTION REQUEST	GN	AH 5.2.02
C	8038 WAS 9215 PROD REQUEST	DW	GN 9.12.98
B	LNMC ADDED	RW	AH 20.7.98
A	LABEL PANEL 57.0 WAS 55.0 AT CUSTOMER REQUEST	AH	GN 20.4.96
REV.	DETAILS	DRN	CKD DATE
SPECIFICATION No.		G533-8038	